



- Designed for feeding of high-speed presses
- Movement transmission to the mobile unit through wheel gear
- Sheet holding through fixed gripper during feeding gripper opening and mobile unit return stroke
- Fixed gripper lifting system through cam
- Pitch adjustment through graduated vernier

RANGE AND FEATURES

Model	Width		Feed length	Thickness		Weight
	Min.	Max.		Min.	Max.	
	(mm)		(mm)	(mm)		(kg)
1621 X	10	132	5 - 130	0.1	2.5	75
1621 A	14	203	5 - 200	0.1	2.5	120
1621 B	30	305	10 - 300	0.2	3.0	235
1621 C	30	407	10 - 400	0.2	3.0	300

DIMENSIONS

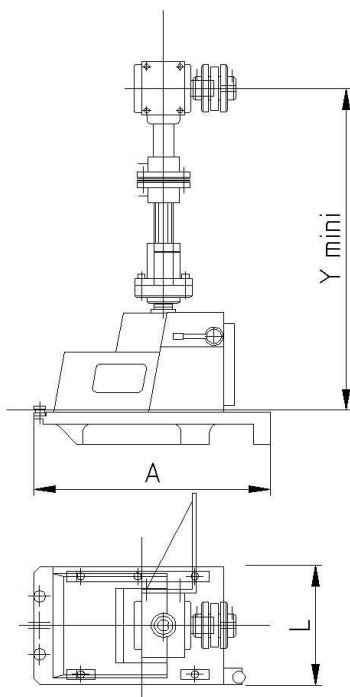

Model	L	A	B
1621 X	295	510	635
1621 A	380	670	645
1621 B	510	880	860
1621 C	610	1080	860